



# THERMAL SYSTEMS

Process Engineering for your processes optimisation needs

Engineering under high pressure

Made in Germany



**ZIRBUS**  
TECHNOLOGY

# ZIRBUS TECHNOLOGY GMBH

Since its founding in 1984, ZIRBUS technology GmbH, as a German manufacturer, has gained an outstanding reputation on the international market. We manufacture not only freeze dryers and autoclaves but also focus on process technology. A steadily increasing number of customers is putting their trust in Zirbus brand autoclaves and lyophilizers.



## Our customers' satisfaction is our top priority...



**TOGETHER WITH OUR CUSTOMERS, WE CONTINUALLY DEVELOP NEW SOLUTIONS FOR VARIOUS AREAS OF APPLICATION**



**WE TAKE ADVANTAGE OF EVERY POSSIBLE OPPORTUNITY FOR IMPROVEMENT**



**PERFECTION IN SERVICE IS WHAT DRIVES US**



**EFFICIENT AND RELIABLE TECHNOLOGY**



**A PERFECT COMBINATION OF SOFTWARE AND HARDWARE**



**TECHNICALLY PERFECTED AND VALIDATABLE PROCESS ENGINEERING**

### CERTIFIED QUALITY

**ASME** certified

**Modul H** certified

**EN ISO 9001** certified

The quality management (QM) system according to DIN EN ISO 9001 implemented and practiced at ZIRBUS technology GmbH provides the framework for our quality- and cost-oriented activities.

In addition, a risk management system is a component of the QM system.

# CONTENT

# PAGE

## **1. STEAM GENERATORS / STEAMBOYS**

**4**

Our compact, Steamboy series electric steam generators are available in sizes ranging from 9-120 kW (12-150 kg/h of steam).

## **2. HIGH-PRESSURE AUTOCLAVES - HDA**

**6**

The high-pressure autoclaves are used in research and production applications, and are produced in direct accordance with your wishes and requirements. Operating at pressures ranging between 4 and 20 bar, our HDA series is suitable for saturated-steam, hot-air and hot water applications.

## **3. CONDITIONING SYSTEMS**

**8**

Steam-conditioning system for polyamide polymers. Conditioning plays an important role in component usability (installation, etc.) and results in high-quality products.

## **4. VACUUM DRYERS - VTA**

**10**

Our vacuum dryers are suitable for use in laboratories in the pharmaceuticals and foods industries. Made of stainless steel, these units are available with either rectangular or round drying chambers. (ATEX optional)

## **5. ROTARY VACUUM CONCENTRATOR (RVC) - ZT**

**12**

Compact rotary vacuum concentrator with integrated solvent condenser for concentrating and drying liquid products. These units are available in two basic versions: horizontal and vertical loading.



**COMPACT DESIGN, THEREFORE LESS SPACE REQUIRED AT THE INSTALLATION**



**PRESSURE VESSEL DESIGN UP TO 8 BAR, OPTIONALLY UP TO 20 BAR**



**HEATABLE FEED WATER TANK TO REDUCE INERT GASES**



**SHORT HEATING-UP TIMES**

Technical data	Steamboy 9	Steamboy 18	Steamboy 22	Steamboy 30	Steamboy 37	Steamboy 50	Steamboy 65	Steamboy 80	Steamboy 120
Dimensions in (W x H x D) mm	400 x 724 x 553	504 x 724 x 853		685 x 1237 x 867			800 x 1725 x 1180		1045 x 1080 x 1845
Electric power kW	9	18	23	30	38	50	60	78	114
Steam performance kg / h	12	24	30	39	49	65	85	102	150
Operating pressure bar (G)	4,5 (optionally up to 20 bar)								
Permissible operating temperature	155 °C								

# The Steamboy steam generator

Our compact, Steamboy series electric steam generators are available in sizes ranging from 9-120 kW (12-150 kg/h of steam).

Maximum permissible operating temperature for standard generators is 155° C at an operating pressure of 4.5 bar. Pressure may also be elevated to a maximum of 20 bar (optional).

The pressure vessel is made entirely of AISI 316L (1.4404) stainless steel. Highly efficient insulation keeps heat dissipation to a minimum. The housing and supporting frame are made of finely brushed AISI 304 (1.4301) stainless steel.



## Ultrapure steam model

- ▶ All steam-conducting valves and pipes are made of AISI 316L (1.4435) stainless steel with orbital welds.
- ▶ The piping system is designed without dead space.
- ▶ Sterilising steam to meet the most sophisticated demands.
- ▶ Bacterial endotoxins < 0.25 EU/ml.

## Steam management system

- ▶ Fully automated microprocessor control unit with touch panel for easy Operation.
- ▶ Operating pressure may be varied between 2,000 mbar and 4,500 mbar (optional: 20 bar).
- ▶ Pressure sensor for infinitely variable pressure measurement.
- ▶ Adjustable output levels.
- ▶ Two steam generators operating in parallel within a network, incl. output adjustment and offtake control.
- ▶ Additional steam reservoir to cover peak with drawal

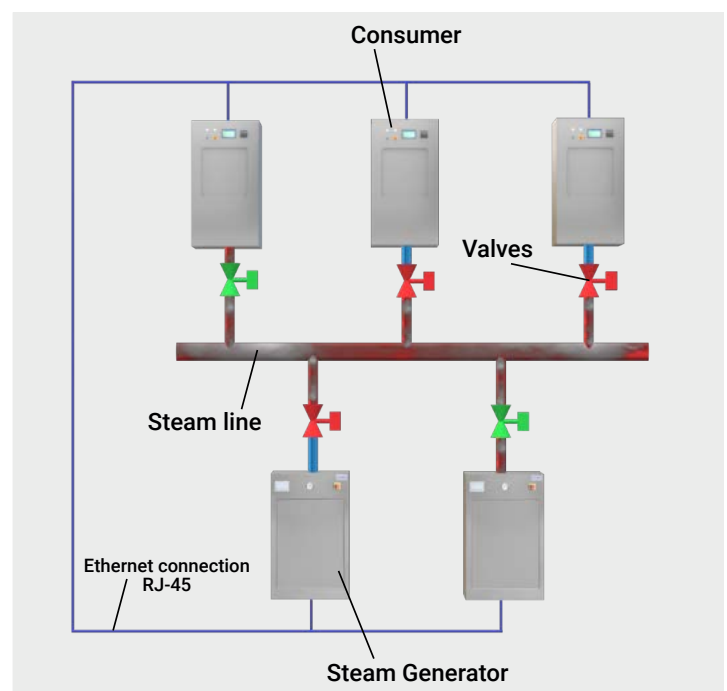

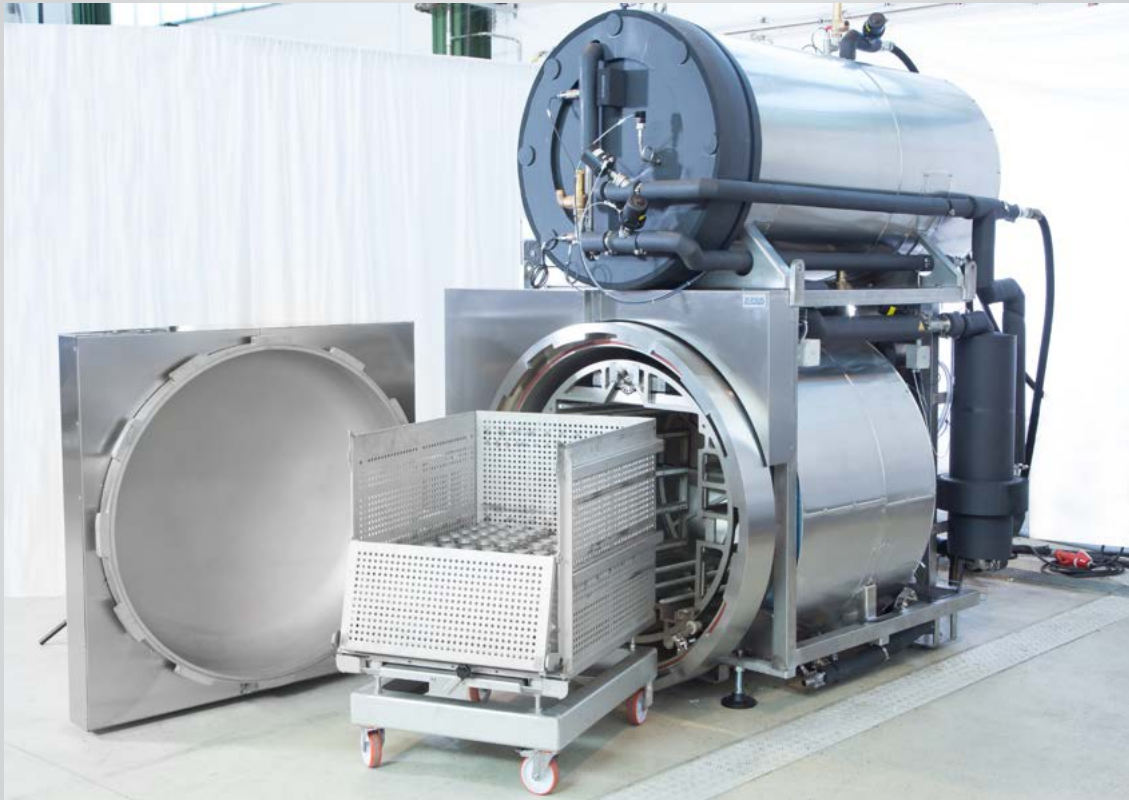

CHAMBER MADE COMPLETELY OF STAINLESS STEEL



PROCESS SEQUENCES ADAPTED TO CUSTOMER REQUIREMENTS



BUILT-IN ROTATING BASKET FOR UNIFORM TEMPERATURE DISTRIBUTION AND HOT WATER SPRINKLING



DIMENSIONS ADAPTED TO CUSTOMER REQUIREMENTS

Technical data	High Pressure Autoclaves
Chamber volume in liters	25 - 12000
Pressure range in bar	up to 20
Temperature range	up to 250° C
Diameter in mm	300 - 1400
Locking system	Bayonet lock
Material	Stainless steel 1.4571/ AiSi 316 oder 1.4404/ AiSi316L
Norms	2014/68/EU & AD2000
Standard diameter in mm	300, 400, 500, 600, 750, 900, 1200, 1400

## High Pressure Autoclaves - HDA

Our high-pressure autoclaves (HDA series) are used in research and production applications and are produced in direct accordance with your wishes and requirements at our plant in Bad Grund.

We build our HDAs to your individual specifications, with operating pressures ranging up to 20 bar(g) and operating temperatures up to 250° C. Our systems are available as either horizontal or vertical models.

A variety of heating systems and various chamber dimensions are available to choose from (Ø 300-1400mm).

May be equipped with a steam generator, steam reservoir, hot-water boiler or hot water cascade.



**Hot air through internal heating elements with a circulating air system**



**Jacket heating in the AL jacket up to 250° C**



**Using hot water and / or superheated steam for saturated steam and / or steam-air mixture processes**

## A variety of heating systems

### ► Hot air: applications

Laminating touchscreen displays and carbon components, also suitable for vacuum processes

### ► Mantle heating: applications

Aging tests

### ► Hot-water vapour: applications

Vulcanising rubber parts  
Materials testing  
Sterilising final products

## Bayonet lock

- Available in a horizontal or vertical configuration.
- Automatic motor for safe opening and closing, meets european safety standards.
- The bayonet is rotated via the cap to minimise seal wear.

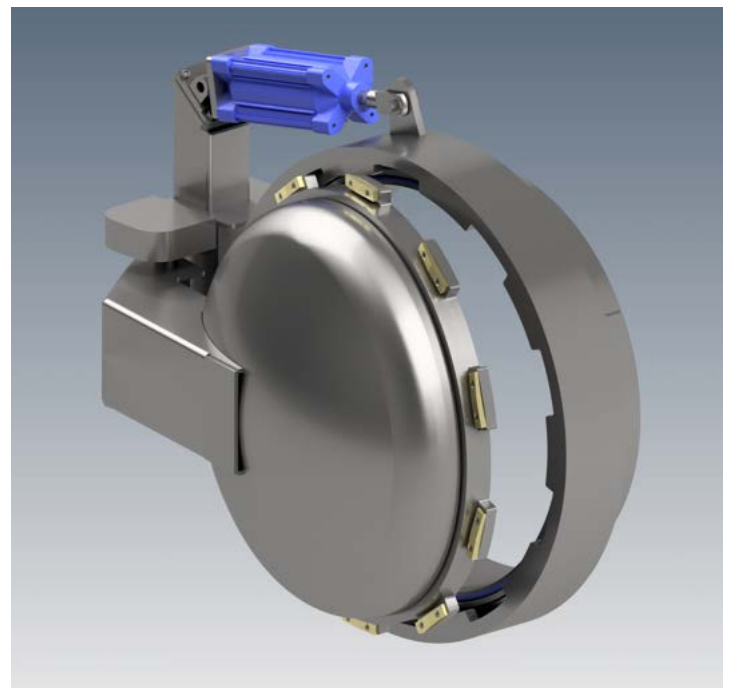

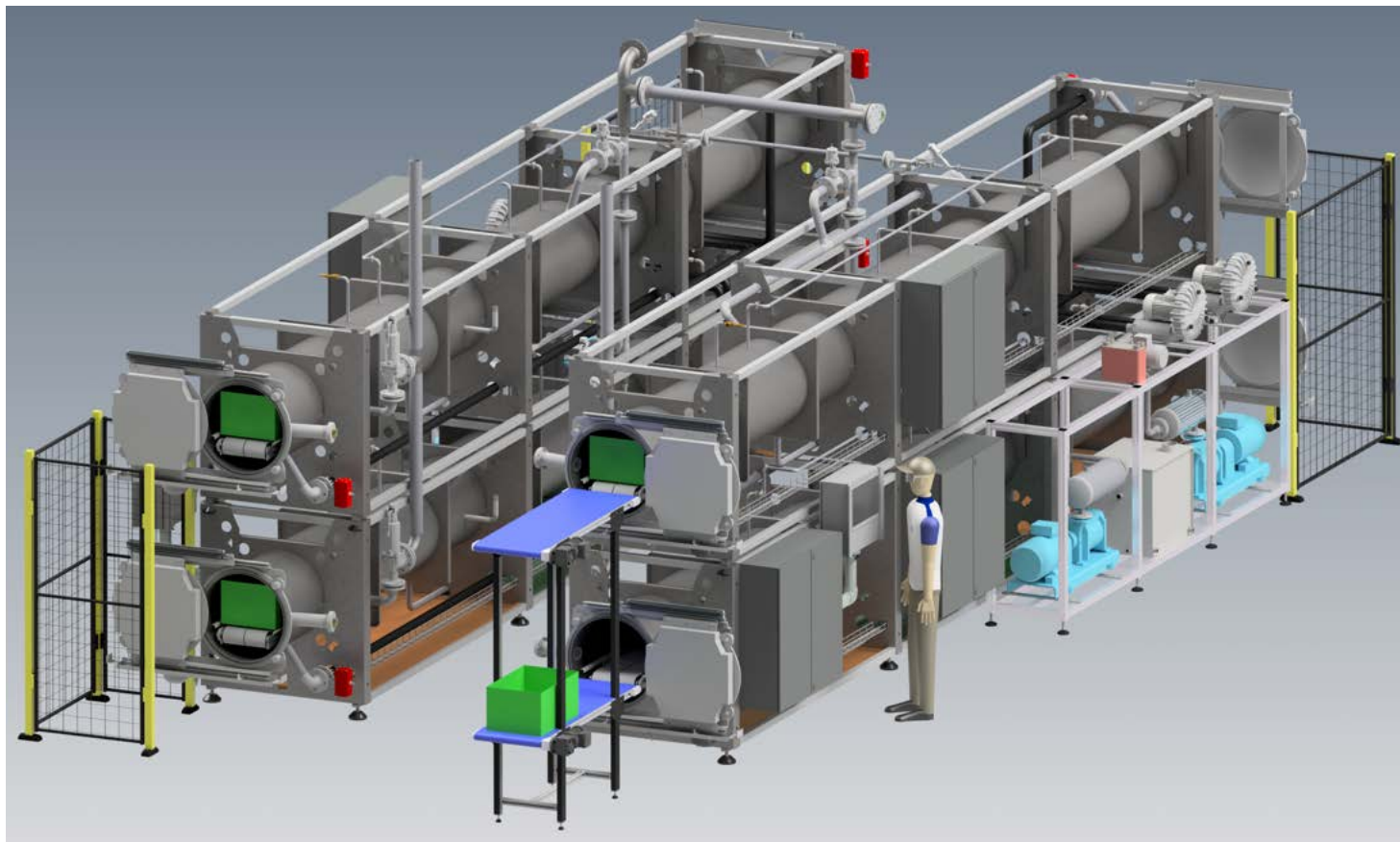

SHORT PROCESS TIMES, < 0.5 HOURS



DEFINED MOISTURE INCREASE THANKS TO VACUUM PROCESS



CHAMBER DIMENSIONS ADAPTED TO KLT CONTAINERS



COMPACT DESIGN WITH FULLY AUTOMATIC LOADING AND UNLOADING

Technical data	JK 1-240	JK 1-330	JK 2-2500
Chamber usable space in mm (W x H x D)	700 x 400 x 850	700 x 550 x 850	Ø 660 x T 9000
Usable volume in liters	240	330	2500
Capacity in pieces	2 KLT boxes normal	4 KLT boxes flat	14 KLT boxes normal
Permissible operating pressure	0 ... 1490 mbar abs.		



## Conditioning systems

Steam-conditioning system for polyamide polymers.

Water absorption has a positive effect on the properties of polyamide parts. Components can be installed immediately after the conditioning process. Conditioning results in high-quality products.

The vacuum-steam process ensures that moisture penetrates the pores of the polymer quickly and evenly.

This reduces warehousing costs and throughput times for the entire manufacturing process.

## Flexible loading and unloading system

- ▶ Automatic loading and unloading system can be connected to an ERP system, etc.
- ▶ Removable shelves, etc., Allow for ergonomic, manual loading.
- ▶ Database system for identifying the product at hand, includes recognition of necessary process parameters.
- ▶ Weighing system for process control.

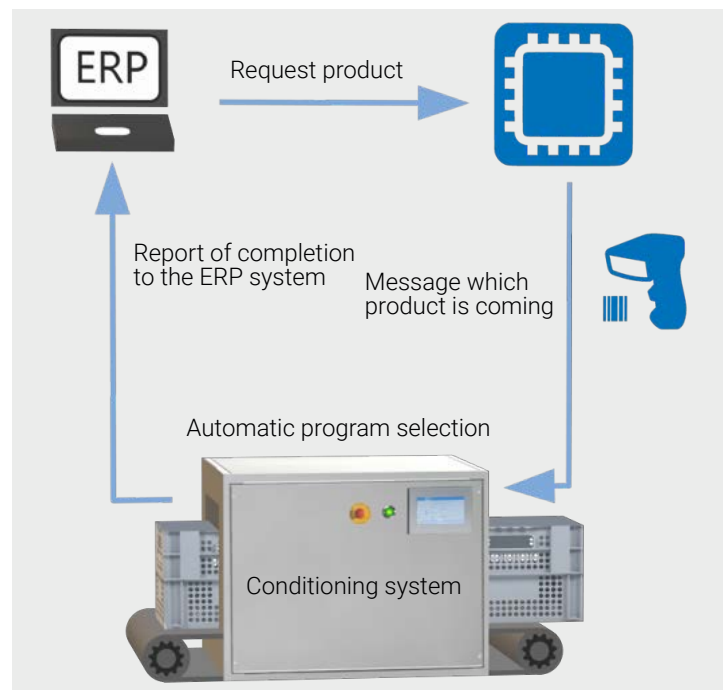

## Dry, spot-free product removal

- ▶ Vacuum and saturated steam feed for an optimised process.
- ▶ Temperature and pressure sensors for optimum conditioning parameter control.
- ▶ An integrated vacuum pump dries product surfaces.

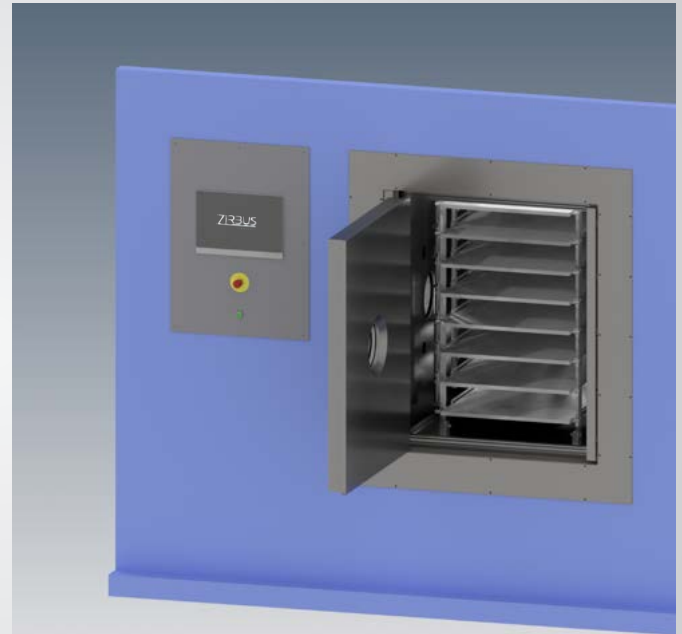
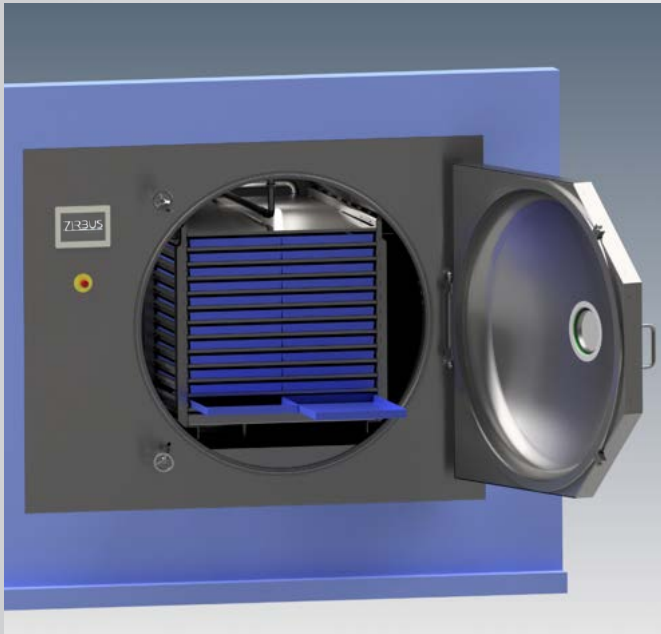

ACTIVE COOLING / HEATING OF THE SHELVES





DIFFERENT HEATING SYSTEMS AVAILABLE



WITH INTEGRATED CONDENSER SYSTEM



EXPLOSION PROTECTION DESIGN

Technical data	Rectangular drying chamber 	Round drying chamber 
Drying method	Contact or radiation drying under vacuum	
Product shelf	1...30m <sup>2</sup>	1...90m <sup>2</sup>
Floor space size	customer-specific	
Material	Stainless steel AiSi 316L (1.4404)	
Temperature range	20...120°C	
Heating	By a heat conductor (water, oil)	

## Vacuum drying systems - VTA

Our vacuum dryers are suitable for use in laboratories in the pharmaceutical and food industries. Units are made from AISI 316L (1.4404) stainless steel. Available with rectangular or round drying chambers.

Products are dried under vacuum using contact and radiation drying techniques. Shelves are heated by means of a heat conductor (water, oil)

The product shelves in our VTA-series vacuum dryers range in size from 1-30m<sup>2</sup>. Liquid-tempered shelves distribute temperature evenly.



## Cleaning in Place - CIP

- ▶ Rotary nozzles clean the walls of the chamber.
- ▶ Fan nozzles are located along the sides of the shelves, each cleaning either the upper or lower surface of a shelf.
- ▶ Removes drying residues from the shelves, in the drying chamber and in the condenser.

## ATEX design

- ▶ Meets Regulation 2014/34/EU.
- ▶ Intrinsically safe design and N<sub>2</sub> gas inerting.
- ▶ Uses an oil-free vacuum pump (ATEX)



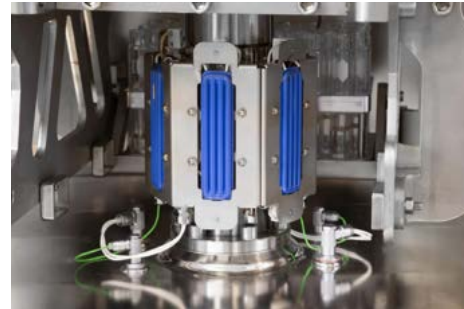
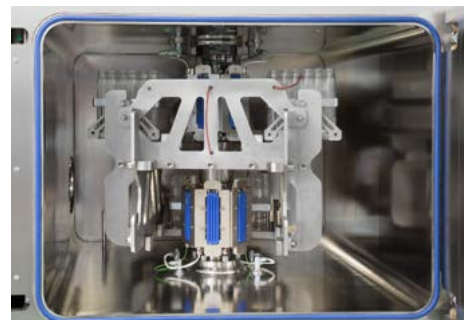

**LARGE CAPACITIES - LOAD VOLUME, RESISTANT TO ANY IMBALANCES**



**DIRECT TEMPERATURE MEASUREMENT IN THE PRODUCT**



**RAPID EVAPORATION OF SOLVENTS THROUGH DIRECT INFRARED HEATING**



**FLEXIBLE LOADING CONFIGURATION E.G. MPT's, ZYMARK TUBES ETC.**

Technical data	ZT-H6	ZT-12
<b>External dimensions (W x H x D) in mm</b>	1400 x 1900 x 1100	1200 x 1000 x 800
<b>Condenser</b>	20 kg	15 kg
<b>Temperature</b>	-75 ° C	-75 ° C

## Rotary - Vacuum - Concentrator (RVC) - ZT

Our ZT12 and ZT-H6 series of rotary vacuum concentrators dry large amounts of solvent gently and quickly from the liquid aggregate state.

Both models are dual-chamber systems. The project chamber and condenser (-75° C) are physically separated from each other. A large-scale flap valve between the chamber and condenser makes it possible to measure the degree of dryness while drying process is still underway.

Both models come with a large touchscreen for intuitive operation and control. A large number of predefined programs are available in addition to user-defined programs.

### Advantages:

- ▶ The rotor system is designed to stay balanced.
- ▶ Customer-specific rotors are available in addition to various standard rotors.
- ▶ A high-performance condenser in combination with directly heated product surfaces and a powerful vacuum system keep process times short.
- ▶ Comes with an optional nitrogen inerting system that includes residual oxygen content measurement.
- ▶ The system is virtually resistant to solvents, as it is made entirely from stainless steel.



### Optimum drying speed

- ▶ Due to optimised flow paths between the chamber and condenser.
- ▶ Direct heat input even under vacuum due to controlled IR units radiating heat directly onto the product surfaces.
- ▶ Contact-free data transfer for temperature measurement within the product, ensuring fast, gentle drying.
- ▶ Automatic defrosting for excellent availability.

### Optimized rotor

- ▶ Designed against unbalance occurring during the process.
- ▶ Three rotor variants available: 2x2 shelf area, 2x3 shelf area, 2x4 shelf area
- ▶ Loading capacities:

	ZT-H6			ZT-12	
	Rotor 1 2x4	Rotor 2 2x2	Rotor 3 2x3	Godel 1	Godel 2
96 Deep Well Mikrotiter plates 41,6 mm	24	12	18	36	/
96 Shallow Well Mikrotiter plates 27,1 mm	40	12	18	36	72
24 Rack for 30 ml Zymark Tubes	/	4	6	/	/
96 Rack for 4 ml Vials	/	4	6	/	/





### After-sales service

Excellent availability and reliability

Optimum, short lines of communication



### Worldwide customer requests

Demand determined with an eye to region-specific requirements

Global partners



### Technical sales

Expert consultation from a team with project experience

Development of customer-oriented solutions for various applications



### Delivery, installation

Our qualified personnel will set up and start up your system



### Engineering

Design meets established standards

Adapted and designed according to customer specifications



### Quality control and assurance

A guaranteed high standard of quality

100% testing of every finished unit

High-quality German engineering



### Instrumentation and control

Ideal synergy between control and process engineering, all with an eye to customer requirements



### Production

Modern mass production - „one-piece flow“

Trained production employees work exclusively at our Bad Grund site



### Vacuum drying system

Model VTA 15  
Area of application: For drying raw materials for the pharmaceutical industry.

The VTA has a total area of 16.2m<sup>2</sup> and is equipped with 12+1 shelves, which can be heated up to 100° C.

The available ice condenser has a temperature of -50° C and a capacity of up to 400kg.

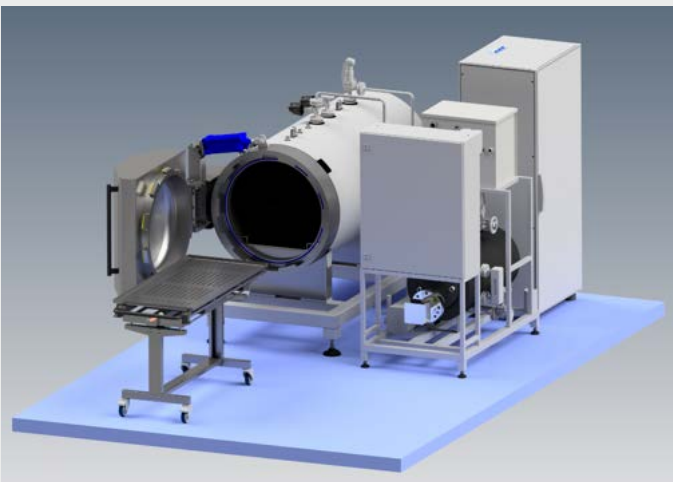

### High pressure autoclave

Model HDA 620 - 17 - 210  
Area of application: Building material testing

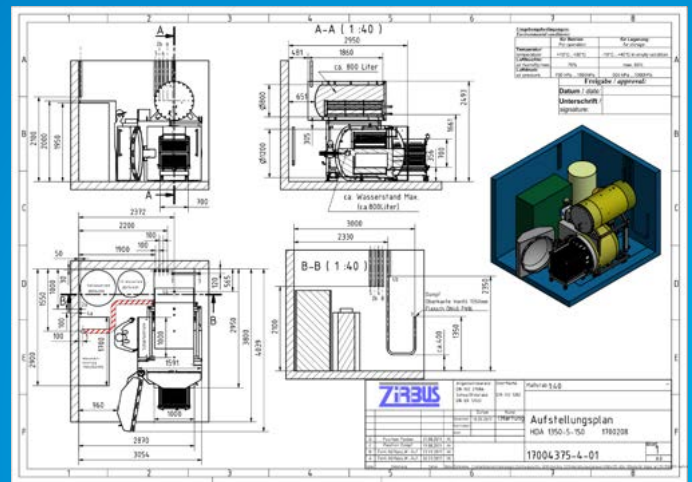

### High pressure autoclave

Model HDA 1350 - 5 - 150  
incl. Rotating basket for sterilizing canned food

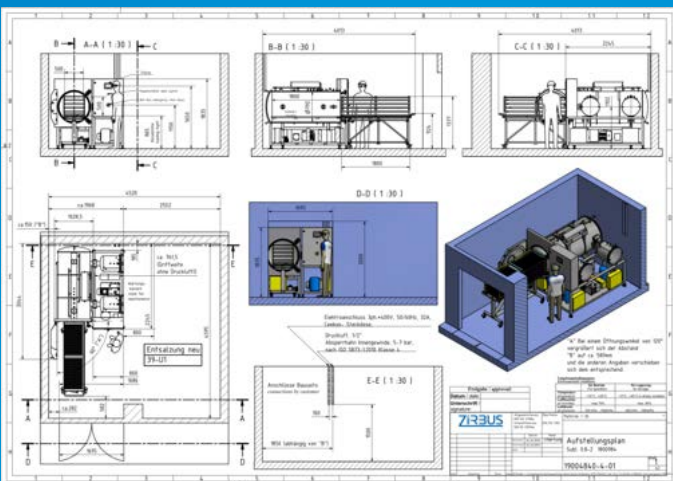

### Freeze drying plant

Model Sublimator 0,8 - 2  
for drying archaeological exhibits



### Conditioning system

Model JK 4-145  
Suitable for the conditioning of plastic parts as bulk goods

To provide reproducible results, the thermal systems processes are individually validated according to DIN EN 17665. The validation is the inspection of the device with regard to its proper functioning. This is performed under real-life conditions with the customer's product in order to check the process parameters.

In doing so, the temperature distribution in the sterilization chamber at various measurement points plays a crucial role. The process requirements are met if the temperature differences are the same as or less than the temperature range specified by the customer.

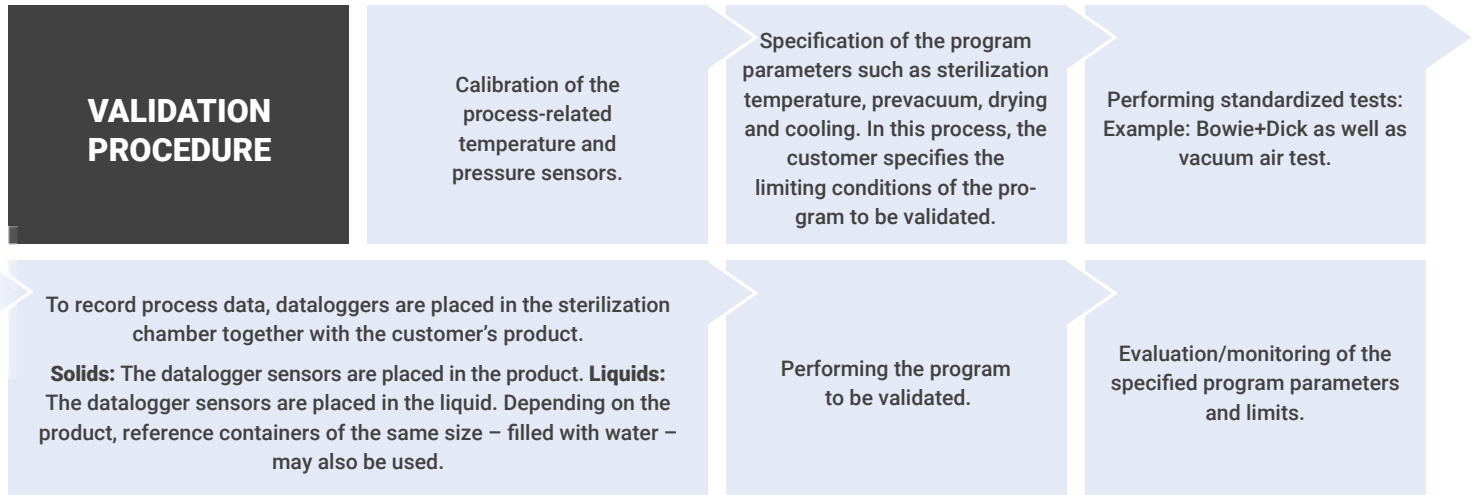

## INDUSTRY PC – IPC DOCUMENTATION SOFTWARE

The IPC is a add-on module of the standard touch screen. With this add-on, additional comprehensive functions are available to the user. In this way, we achieve the best possible combination of software and hardware for you for controlling and monitoring your processes.

### EXPANDED OPTIONS

Independent documentation (analog values) of temperature and pressure

Batch documentation as PDF and CSV file

Automatic printout of batch documentation after the end of the program

Expandable storage module to file the batch logs

99 formulations can be defined as desired

Integration in the network and thus possible remote maintenance of the entire system

Optional user management to set up different user groups



The batch documentation consists of a graphic representation of the temperature and pressure gradients. On the second page of the documentation, the individual program steps are listed in table form. If a value should be outside of the target value, this is automatically marked in red. Included in the batch log is also a personalized signature field for acknowledging batches.



Qualification serves as proof that the manufactured system meets the requirements agreed on and that the performance characteristics as well as the versions are compliant. The qualification is performed according to DIN EN 58950-3 and GMP guidelines.

<p><b>DESIGN- QUALIFICATION (DQ)</b></p>	<p>Specification of the requirements for the system in the form of a DQ plan/specifications. Comparison of the requirements by means of DQ report/specifications, alternative offer (SDS, FDS, HDS).</p>
<p><b>INSTALLATION QUALIFICATION (IQ)</b></p>	<p>During the IQ, it is documented that the system, as it is installed, matches the information in the specifications and the requirements from the DQ.</p> <ul style="list-style-type: none"> <li>· Material documentation</li> <li>· Calibration</li> <li>· Review of the piping plan</li> </ul>
<p><b>OPERATION QUALIFICATION (OQ)</b></p>	<p>During the OQ, it is documented that the system is fully functional. This includes tests to be performed which are as realistic as possible or which are to be performed under routine manufacturing conditions.</p>
<p><b>PERFORMANCE QUALIFICATION (PQ)</b></p>	<p>Within the PQ, the validation report is generated with the customer's product and proof is provided that the system meets the targeted performance parameters.</p>
<p><b>FACTORY ACCEPTANCE TEST (FAT)</b></p>	<p>Acceptance of the system in the manufacturing factory according to the FAT protocol. Here the proper functioning and design of the system are reviewed together with the customer.</p>
<p><b>SYSTEM ACCEPTANCE TEST (SAT)</b></p>	<p>The SAT includes the implementation of the IQ and OQ at the customer's final installation location. A Zirbus employee qualified to perform this task conducts the qualification of the system on site together with the customer. In this process, he/she verifies the proper functioning according to the requirements specified by the customer.</p>
<p><b>REQUALIFICATION</b></p>	<p>During requalification, it is ensured that the system is still in a qualified condition following changes. Quality-related system parameters are assessed and evaluated. In general, the requalification consists of the same tests which were already performed during the initial qualification.</p>
<p><b>CONFIGURATION SPECIFICATION</b></p>	<p>The configuration specification has replaced the earlier customary documents of the hardware design specification (HDS) and software design specification (SDS). The following parameters are described here, as a matter of priority:</p> <ul style="list-style-type: none"> <li>· Hardware components and versions</li> <li>· Firmware versions</li> <li>· Software versions</li> <li>· Description of the sensors</li> <li>· Description of the performance parameters</li> <li>· User profiles</li> </ul>
<p><b>FUNCTIONAL DESIGN SPECIFICATION (FDS)</b></p>	<p>In the case of the FDS, the system manufacturer confirms the correct execution of the system according to the customer's specifications. The features of the system are described and performance parameters as well as components used are defined and documented.</p>

Available in five versions to fit your needs.



## BATCH PRINTER

Generates an informative paper printout with all relevant data at the end of the process.



## STERILOG

BATCH DOCUMENTATION SOFTWARE

Windows-based software automatically reads the process data from the autoclave and processes these data into a graphic and numeric PDF log (direct coupling with the Ethernet interface RJ45).



## USB MEMORY CARD

To record process data on a USB stick at an integrated USB port of the autoclave; includes "SteriLog" evaluation software.



## INDEPENDENT DOCUMENTATION

The measured values for temperature and pressure for batch documentation are recorded independently of the SPS control according to DIN EN 285. This enables independent recording of three temperature sensors and a pressure sensor.



## 10-CHANNEL SCREEN PRINTER

GMP-COMPLIANT

To ensure GMP-compliant documentation, this must be performed according to FDA 21 CFR Part 11 and GMP.

It must be ensured that the documented process data cannot be manipulated in any way. The system must be protected from unauthorized access and monitored with the aid of audit trails. Any user activities are documented and recorded. Electronic signatures can be used to confirm formulations.



**SERVICE**

We offer you outstanding service. Our employees regularly take part in training sessions to make high-quality service possible.

**HOTLINE**

Our technical hotline will assist you regarding operation and if you are having system- or process-related problems. If you need us, we can get to you within 24 hours.

**REPLACEMENT PARTS**

We process spare parts deliveries immediately. Delivery is generally made the same day.

**CONSULTATION**

We can provide you with advice regarding your project and draw on our experience to assist you. Sample sterilizations can also be carried out in our application laboratory.

**OUR SERVICES INCLUDE:**

Delivery, installation and training	Maintenance and Service
Calibration with DKD (German Calibration Service)-tested measuring instruments	Validation according to recognized guidelines
Qualification DQ / IQ / FDS, SDS, HDS /OQ / PQ according to GMP guidelines	Customized process development and optimization
Sterilization and drying on a contract basis in our own application laboratory	





**ZIRBUS technology GmbH**  
**Hilfe Gottes 1**  
**37539 Bad Grund / Harz**

Telephone +49 (0)5327 83 80 – 0  
Telefax +49(0)5327 83 80 – 80  
E-Mail [info@zirbus.de](mailto:info@zirbus.de)  
Internet [www.zirbus.de](http://www.zirbus.de)

